

High efficiency grease and smoke removal



*Plasma Clean Air is continuously improving its products and services and reserves the right to alter designs without prior notice

Our ESP Kitchen Air Cleaner range is an ideal product for removing air pollutants such as grease, smoke and oil from commercial kitchen extract systems, and collects particles as small as 0.01 micron. According to the type and volume of cooking, single-stage, double-stage or triple-stage purification can be selected, to ensure effective purification.

An innovative extra depth-collector cell helps make our electrostatic filters (ESPs) highly effective at removing grease and smoke particulates from kitchen extraction systems whilst maintaining a low pressure drop and low power consumption.

Benefits

- An extra depth collector cell for extra efficiency
- Low pressure drop – 65Pa per pass, for lower energy costs
- Stainless-steel spike ionisers for longer life
- Solid-state power supply
- Two-year parts warranty

Related products

Electrostatic Precipitator ESP UV

The full works - powerful grease, smoke and odour control - in one neat, integrated package.

[Find out more](#)



plasma-cleanair.com · ask@plasma-cleanair.com | 0800 652 3325
Earl Business Centre, Dowry Street, Oldham, OL8 2PF



ESP 3500

designed for in-duct installation where other external sources provide air movement. It has a single combined aluminum ionizer/collector cell with stainless steel spiked ionizers and an air volume range of up to 0,7m³/s for high grease and smoke content.

Specifications	
Dimensions (mm)	560D x 643W x 534H
Installation	Suspended, wall, frame, or duct mounted
Unit weight (kg)	50
Input voltage	220-240V/50Hz/1PH
Ionizer/collector output voltage	12kV/6kV
Product power (w)	30
Number of cells	1
Airflow (m ³ /s)	up to 0,7m ³ /s
Pressure drop (Pa)	≤65
Flange size (mm)	499 x 534
Controls	Power switch with an indicator light
Pre-filter	460L x 460W x 22.2D Standard aluminum mesh Heavy oil filter (optional)
Primary filter	Standard forever filter – electronic ionizer/collector cell
After-filter	Activated carbon plate filter (optional)
Power supply	High-frequency solid-state design
Efficiency	To 95% based on ASHRAE 52.2 To 99% for double pass (calculated)
Construction	Welded galvanized steel, 1.2mm (18 gauge) top/bottom, 1.5mm (16 gauge) columns
Finish	Blue epoxy powder coating (RAL 5017)
Particle size	0.01 to 10 microns
General	Multiple units can be joined together for increased volume or higher frequency

Transformation Pieces (by others):

outwork transitions to and from the ESP to support imalar airflow in accordance with oW/144 (22,5 deg. to 30 deg. maximum)

Installation

ESP to be located at least 1m from any bend to support laminar airflow

IPX4 protection rating. Please consult with Plasma Clean Air representative for outdoor installation.

FRONT VIEW



TOP VIEW

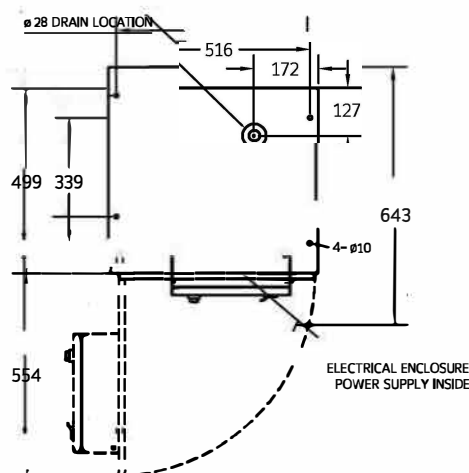

DISCHARGE END

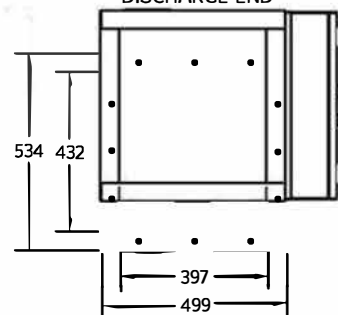

INTAKE END

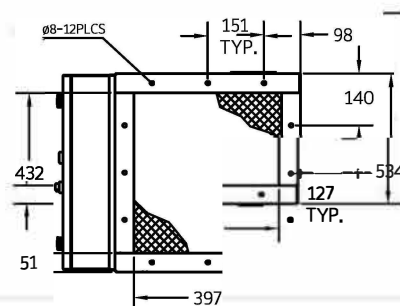

ESP 7000

Designed for in-duct installation where other external sources provide air movement. It has two combined aluminum ionizers/collector cells with stainless steel spiked ionizers and an air volume range up to 1.4m³/s for high grease and smoke content.

Specifications

Dimensions (mm)	560D x 1,103W x 534H
Installation	Suspended, wall, frame, or duct mounted
Unit weight (kg)	70
Input voltage	220-240V/50Hz/1PH
Ionizer/collector output voltage	12kV/6kV
Product power (w)	50
Number of cells	2
Airflow (m ³ /s)	1.4m ³ /s
Pressure drop (Pa)	≤65
Flange size (mm)	959 x 534
Controls	Power switch with an indicator light
Pre-filter	2 x (460L x 460W x 22.2D) Standard aluminum mesh Heavy oil filter (optional)
Primary filter	Standard forever filter - electronic ionizer/ collector cell
After-filter	Activated carbon plate filter (optional)
Power supply	High-frequency solid-state design
Efficiency	To 95% based on ASHRAE 52.2 To 99% for double pass (calculated)
Construction	Welded galvanized steel, 1.2mm (18 gauge) top/bottom, 1.5mm (16 gauge) columns
Finish	Blue epoxy powder coating (RAL 5017)
Particle size	0.01 to 10 microns
General	Multiple units can be joined together for increased volume or higher frequency

Transformation Pieces (by others):

outwork transitions to and from the ESP to support imalinar airflow in accordance with $\rho W/144$ (22,5 deg. to 30 deg. maximum)

Installation

ESP to be located at least 1m from any bend to support laminar airflow

IPX4 protection rating. Please consult with Plasma Clean Air representative for outdoor installation.

FRONT VIEW

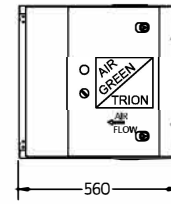

TOP VIEW

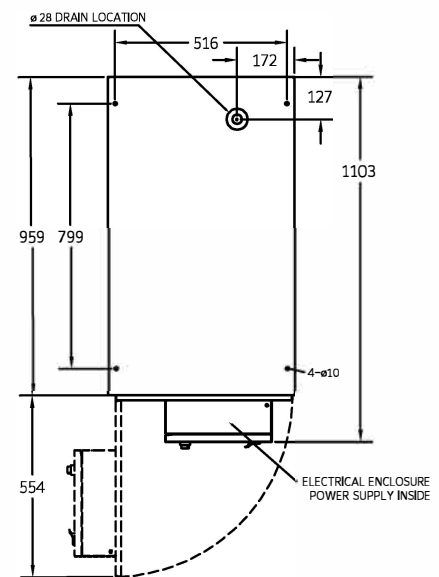

DISCHARGE END

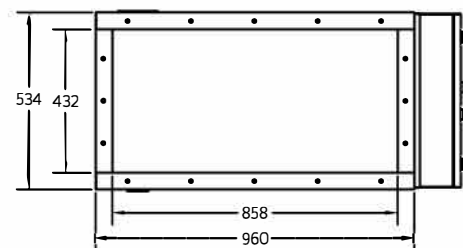

INTAKE END

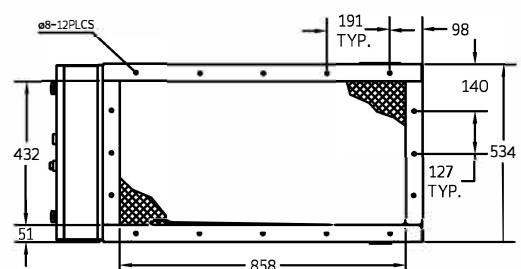

ESP 10500

Designed for in-duct installation where other external sources provide air movement. It has three combined aluminum ionizers/collector cells with stainless steel spiked ionizers and an air volume range up to 2.1m³/s for high grease and smoke content.

Specifications	
Dimensions (mm)	560D x 1,564W x 534H
Installation	Suspended, wall, frame, or duct mounted
Unit weight (kg)	105
Input voltage	220-240V/50Hz/1PH
Ionizer/collector output voltage	12kV/6kV
Product power (w)	70
Number of cells	3
Airflow (m ³ /s)	up to 2.1m ³ /s
Pressure drop (Pa)	≤65
Flange size (mm)	1,420 x 534
Controls	Power switch with an indicator light
Pre-filter	3 x (460L x 460W x 22.2D) Standard aluminum mesh Heavy oil filter (optional)
Primary filter	Standard forever filter – electronic ionizer/ collector cell
After-filter	Activated carbon plate filter (optional)
Power supply	High-frequency solid-state design
Efficiency	To 95% based on ASHRAE 52.2 To 99% for double pass (calculated)
Construction	Welded galvanized steel, 1.2mm (18 gauge) top/bottom, 1.5mm (16 gauge) columns
Finish	Blue epoxy powder coating (RAL 5017)
Particle size	0.01 to 10 microns
General	Multiple units can be joined together for increased volume or higher frequency

Transformation Pieces (by others):

ductwork transitions to and from the ESP to support imalar airflow in accordance with dW/144 (22,5 deg. to 30 deg. maximum)

Installation

ESP to be located at least 1m from any bend to support laminar airflow

IPX4 protection rating. Please consult with Plasma Clean Air representative for outdoor installation.

FRONT VIEW

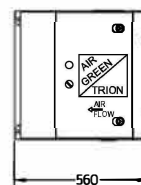

TOP VIEW

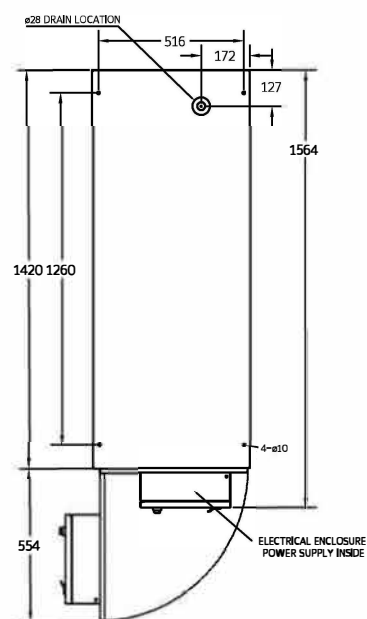

DISCHARGE END

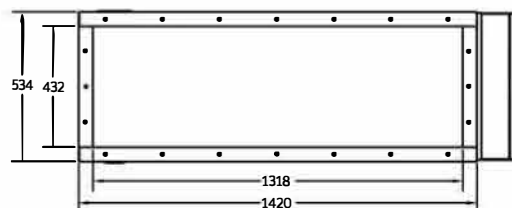

INTAKE END

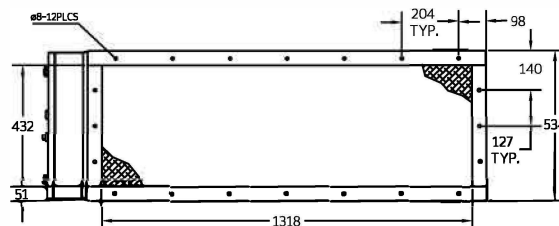

ESP 14000

Designed for in-duct installation where other external sources provide air movement. It has four combined aluminum ionizers/collector cells with stainless steel spiked ionizers and an air volume range up to 2.8m³/s for high grease and smoke content.

Specifications

Dimensions (mm)	560D x 2,025W x 534H
Installation	Suspended, wall, frame, or duct mounted
Unit weight (kg)	145
Input voltage	220-240V/50Hz/1PH
Ionizer/collector output voltage	12kV/6kV
Product power (w)	90
Number of cells	4
Airflow (m ³ /s)	up to 2.8m ³ /s
Pressure drop (Pa)	≤65
Flange size (mm)	1,881 x 534
Controls	Power switch with an indicator light
Pre-filter	4 x (460L x 460W x 22.2D) Standard aluminum mesh Heavy oil filter (optional)
Primary filter	Standard forever filter - electronic ionizer/collector cell
After-filter	Activated carbon plate filter (optional)
Power supply	High-frequency solid-state design
Efficiency	To 95% based on ASHRAE 52.2 To 99% for double pass (calculated)
Construction	Welded galvanized steel, 1.2mm (18 gauge) top/bottom, 1.5mm (16 gauge) columns
Finish	Blue epoxy powder coating (RAL 5017)
Particle size	0.01 to 10 microns
General	Multiple units can be joined together for increased volume or higher frequency

Transformation Pieces (by others):

ductwork transitions to and from the ESP to support imalar airflow in accordance with DW/144 (22,5 deg. to 30 deg. maximum)

Installation

ESP to be located at least 1m from any bend to support laminar airflow

IPX4 protection rating. Please consult with Plasma Clean Air representative for outdoor installation.

FRONT VIEW

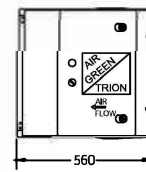

TOP VIEW

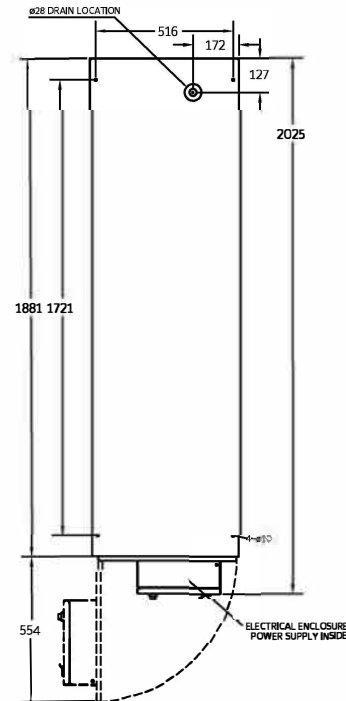

INTAKE END

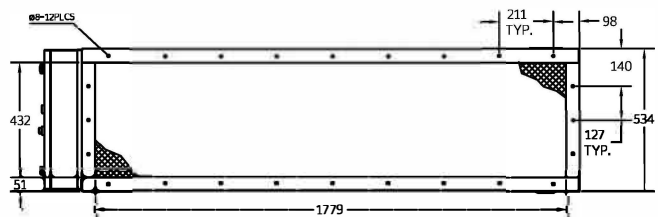

DISCHARGE END

